

Introduction	3
Instrument overview	4
Keyboard	5
Operating philosophy	5
Run mode (normal operating mode)	5
Setting mode (for adjustments)	5
Option mode	6
Commissioning	6
The altimeter	7
General remarks	7
How does an altimeter work?	7
Altimeter 1 (ALT1)	8
Setting mode	8
Option mode	9
Altimeter 2 (ALT 2)	9
Setting mode	10
Option mode	10
Vario and Polar	11
Vario sound levels	11
Analog vario bar display	11
Digital vario display (Integrator)	11
Setting mode	12
Option mode	12
Descent tone/Descent alarm and Polar	13
Setting mode	13
Option-Mode	13
Speedometer	14
General remarks	14
Display	14
Correction	14
Setting mode	14
Option mode	15
Time measurement and temperature display	16
Clock time (real-time clock), Stopwatch (CHRONO), Flying time	16
Temperature display	16
Setting mode	17
Option mode	17
GPS-supported functions	18
Introduction	18
Connection to a GPS navigation receiver	18

Normal flight according to McCready	19
Theory	19
Introduction	19
Abbreviations	19
The polar and its interpretation	19
Working out the polars	20
Polars for the best glide in still and agitated air	21
Optimum cruising speed	21
MacCready nominal flight display	22
Descent phase	22
MacCready nominal flight instrument setting	22
Weighting of the wind component compensation	23
Final approach	23
Theory	23
Introduction	23
Final approach computer display	23
Ascent phase	23
Descent phase	24
Final approach computer: instrument settings	25
With or without head wind component	25
Logbook	26
General remarks	26
Printout	26
Barograph	27
Recording	27
Time marker	27
Printout	27
Transmission to a PC	28
Barograph setting mode	28
Barograph option mode	28
APPENDIX	29
Scope of supply	29
Procedure for Official FAI Observers	30
Water damage	30
ASCII table	31
PC and printer interface	31
Function overview	32

Introduction

Flytec's 4030 is a completely new development. The new instrument is now more compact, lighter and more economical thanks to the use of the very latest technology.

The 4030 is an instrument which you can adjust to suit your requirements. For this reason, all important data can be altered quickly and easily. You're flying in the United States? No problem: Altimeter 1 displays the altitude in feet and Altimeter 2 displays the meters to which you are accustomed! This is just one example of what the 4030 has to offer.

With this new instrument, we have remained loyal to Flytec's operating philosophy - and also improved it with the new option mode. Flytec's new 4030 is an instrument that will give you immense enjoyment.

Your Flytec team



Instrument overview

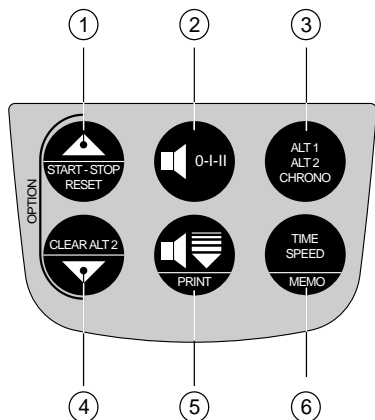

1. On/Off switch
2. Analog vario bar display
3. Digital vario display, Glide ratio display
4. INDICATOR display
5. TIME / SPEED / MEMO display
6. Altimeter & stopwatch display
7. Key
8. Speed sensor Socket
9. PC, printer and GPS interface
10. REC switch

Keyboard



- 1 START-STOP-RESET
- 2 VARIO
- 3 ALT1-ALT2-CHRONO
- 4 CLEAR ALT 2
- 5 SINK (PRINT)
- 6 TIME / SPEED / MEMO

Operating philosophy

The philosophy behind all Flytec instruments is to keep everything as simple as possible. This is why each key has only one function, i.e. a function can be displayed and switched on or off with each key. In order to alter a function, you press and hold down the relevant function key for approximately 3 seconds. The setting to be changed will then flash and can be altered by pressing  and .

The instrument has three operating modes: normal operating mode, setting mode and configuration mode.

Run mode (normal operating mode)

The instrument is in run mode when used in normal operation. In run mode, the instrument will display your altitude, ascent and the time continuously.

Setting mode (for adjustments)

In setting mode, the most important value can be changed for each display. For example, the altitude can be set by using the setting mode for altimeter 1.

Enter setting mode for a particular display (e.g. for altimeter 1), by pressing the relevant function key (e.g. ) and holding it down for about 4 seconds. As soon as you are in setting mode, the SET indicator will appear in the INDICATOR display. The value to be changed begins to flash.

In order to return to run mode, press the relevant function key briefly (e.g. )

If no change is made in setting mode for 15 seconds, the instrument returns to run mode.

Option mode (configuration mode)

Option mode allows you to configure the instrument to your requirements and preferences. In option mode, you can set the parameters for the relevant display or function at various levels. For example, these can be units or special functions. A precise description of the various settings in option mode is given in the descriptions of the individual functions.

You can enter option mode (in the setting mode of a function) by simultaneously pressing the two keys marked "Option" in yellow (Fig. 1). If the instrument is in option mode, this is confirmed by the OPTION indicator in the INDICATOR display.

In OPTION mode you can change several parameters. By briefly pressing the relevant function key (e.g. ) you skip from one level to the next. In each level you can change one parameter of the relevant function. The level number will appear each time in the digital vario display.

If no change is made for 15 seconds in option mode, the instrument returns to run mode.

In order to return to run mode manually, press the two option keys simultaneously again (Fig. 1).

Using FlyChart 4.0 software on a PC, all settings in setting and option modes as well as additional configurations can be conveniently set and transmitted to the instrument via the PC interface.

Commissioning

Switch on the instrument with the On/Off switch. On being switched on, the instrument goes through a self-test routine and then enters run mode.

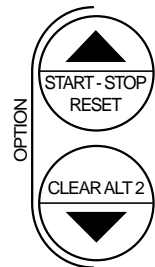

Figure 1

When switched on, the instrument settings correspond to those valid when the instrument was last switched off.

When first switched on, the instrument displays the approximate charging status of the batteries in the vario bar display. If the display shows approximately 50% of the maximum display in the green sector, the batteries are still half full. If the display is in the red sector, the batteries must be changed. If the batteries are low on charge during a flight, PO will light up briefly in the digital vario display and, at the same time, the charging status of the batteries is shown in the bar display.

The battery life of the instrument using alkaline batteries is 160 hours. Rechargeable batteries can also be used. However, operating time is substantially shorter with these (total operating time is approximately 40 - 50 hours).

Alkaline batteries can also be recharged several times using the appropriate charging unit (no fast chargers!).

The altimeter

General remarks

How does an altimeter work?

An altimeter is really a barometer because it does not measure altitude directly but pressure. The altitude is then calculated from the pressure. For the purpose of calculating absolute altitude (according to the international formula for altitude), the pressure at sea-level is assumed as being zero-point pressure.

Why does pressure change with altitude? The air pressure at a point on Earth is produced by the weight of the atmospheric air above it. This is why air pressure decreases with altitude - there is less air above your head! At 500 meters above sea-level, a pressure change of 1 mbar corresponds to a difference in altitude of about 8 meters.

In practice, however, it is not quite that simple as other factors also have an influence on air pressure. Pressure also depends on temperature and, of course, weather. On a stable day, there can be air pressure fluctuations of 1 mbar caused by temperatures and this corresponds to a difference in altitude of ± 10 meters. Depending on the weather, air pressure at sea-level (QNH) can be between 950 mbar and 1050 mbar. In order to eliminate this weather effect, an altimeter needs continual recalibration. This means that the altimeter must be set at a known altitude to display that same altitude.

When the weather changes fast (e.g. cold fronts), air pressure can change in the course of a day by up to 5 mbar. This represents a change in altitude of 40 meters!

Another method of calibrating an altimeter is by entering the current QNH. What is the QNH? In flying circles, a general zero point is needed to enable all aircraft at the same altitude to also have the same altitude on their altimeters. This joint basis is called the QNH. The QNH is the current air pressure in hPa (1 hPa = 1 mbar) calculated at sea-level. It is redetermined several times daily and can be obtained in the flying weather report or from airfields by radio.



Altimeter 1 (ALT 1)



Altimeter 1 displays absolute altitude, i.e. the altitude above sea-level.

Function key  is used to change from the displays for altimeter 1, altimeter 2 and the stopwatch. Pressing and holding down this key will make the instrument go into setting mode.

Attention: While a flight is being recorded (REC activated) the setting mode is blocked for Altitude 1. This altitude can only be readjusted after the REC has been switched off. This is an FAI requirement.

Altimeter 1 setting mode

As mentioned above, the **absolute altitude can be set** in setting mode. The altitude and the QNH flash on 2 lines. Using the setting keys  and , you can set the altitude and the QNH simultaneously. If you do not know what altitude you are currently at, you can set the altitude using the QNH but this method is not as precise as direct altitude setting. The QNH has a resolution of 1 mbar which corresponds to an altitude resolution of approximately 8 meters. The altitude, however, can be set directly to an accuracy of 1 meter.

Pressing the setting keys  and  simultaneously will take you from setting mode to option mode.

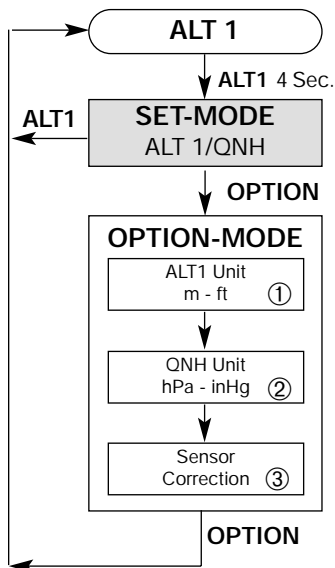

Altimeter 1 option mode

In option mode, you can set the unit for ALT 1 (meters or feet) at the first level and, at the second level, you can set the unit for the QNH (hPa or inHg). The indicator for the relevant unit set flashes in the display.

The pressure sensor can be corrected at the third level (± 50 hPa).

If you find that the QNH value displayed at a known altitude deviates seriously from the QNH value of a weather station in your area, you can correct this deviation by entering the deviation (with a different prefix). I.e. if the QNH displayed by your instrument is 20 hPa too high, enter -20 to correct this deviation.

This deviation is caused by the aging of the pressure sensor and stabilizes after 2 - 3 years.



N. B.: Incorrect manipulation of the correction value of the pressure sensor will result in false altitude readings! Never alter the basic settings of the altimeter unless you have good reason to do so (in your own interest)!

In option mode, the indicators OPTION and ALT 1 appear and the relevant number of the module is shown at the top of the display. The unit to be adjusted will flash.

Altimeter 2 and target altitude (ALT 2)

Altimeter 2 can either be used as an absolute altimeter or as a relative altimeter.

When used as an absolute altimeter, it functions in precisely the same way as altimeter 1. Altimeter 2 can now, for example, display the altitude in feet and altimeter 1 the altitude in meters.

The relative altimeter displays the current altitude with reference to a point. This reference point can be set at zero in run mode at any time by using the  key or set at any altitude in setting mode. The relative altimeter can thus be used to measure the higher altitude of the take-off area. Pressing the  key at the take-off area will zero ALT 2 for this purpose.

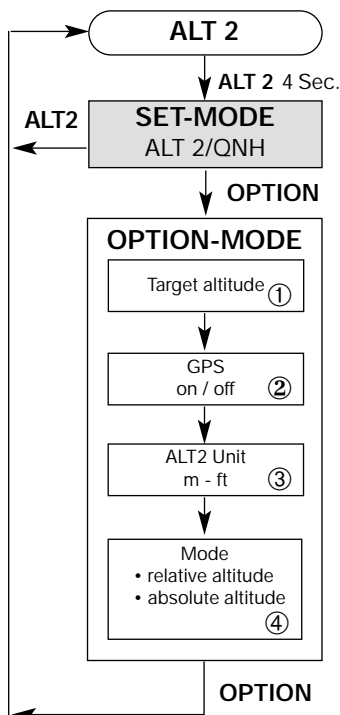



Altimeter 2 setting mode



The altitude can be set in setting mode in precisely the same way as with altimeter 1.

If altimeter 2 is selected as the absolute altimeter, it is coupled to altimeter 1. Any change in the display for altimeter 1 is reflected by a corresponding change in the display for altimeter 2 and vice-versa.

Altimeter 2 option mode

In OPTION mode, you can enter the target altitude at the first level using the  key and the  key.

Use the  key to enter the second level of OPTION mode. There, the GPS-supported functions of the instrument can be switched on or off.



The unit of the ALT 2 display (meters or feet) is determined at the third level. The currently selected unit flashes in the display. Use the  or the  key to toggle between the units.

Press key  to enter the fourth level of option mode. At this level, you select the operating mode of altimeter 2. If this is set at absolute altimeter, the two indicators ALT 1 and ALT 2 will flash in the display. If set at relative altimeter, only the indicator ALT 2 will flash.

You return from option mode to run mode by waiting 15 seconds or again pressing the two keys marked "OPTION" simultaneously.

Vario and Polar

Vario sound levels

Two sound levels can be set or the sound system switched off completely by repeatedly pressing the  key. While the  key is pressed, a tone will sound at the desired level.

Analog vario bar display

The vario bar display has a range of ± 8 m/s in two scale passes. The scale unit always corresponds to 0.2 m/s. Up to 4 m/s, the bar display fills. If it displays more than 4 m/s (ascent), the ascent is displayed inverted, i.e. the display is full at 4 m/s and empties from below when ascent increases.

E.g.:

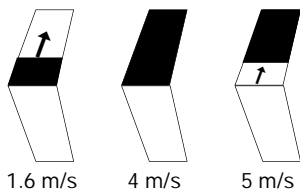

The sensitivity of the bar display corresponds to the basic attenuation of the vario (\ddagger setting mode of the vario). It therefore always displays current ascent.

Digital vario display (Integrator)

The digital vario displays the attenuated climb rate for the last X seconds in second rate. The time X, via which ascent is attenuated (integration time), can be changed at the first level of option mode. These values appear flashing in the digital vario display.

Vario setting mode



You can enter the vario's setting mode by pressing the  key for a long time (approximately 3 seconds). This automatically activates the final approach computer (on) or, if pressed again, deactivates it (off). The preset wind component is shown in the SPEED display for the purpose of information.

You can enter option mode by simultaneously pressing the two option keys.

Vario option mode

The basic attenuation of the vario can be altered at the first level of option mode. The basic attenuation of the vario is effective on all vario functions; it can be set to 0.5 sec, 1 sec or 1.5 sec.

N.B.: The fastest vario is not always the best vario. In very rough and severe conditions, it is advisable to attenuate the vario more. Turbulences are then filtered out by the attenuation and not displayed.

The integration time of the digital vario can be altered at the second level of option mode. The values are in 5-second steps between 5 and 35 seconds and appear flashing in the digital vario display. At setting 1, the digital vario is displayed without averaging and then runs parallel to the bar display. The values can be altered with the  and the  keys.

The audio response point can be adjusted at the third level. The audio response point can be adjusted from +2 cm/s to +40 cm/s. The current response point appears in the bar display and represents one tenth of the value displayed. E.g.: a display of 2 m/s corresponds to an audio response point of 20 cm/s.

The digital vario unit can be selected at the fourth level: m/s or feet/min x 100. The current setting flashes in the digital vario display. You can switch between the two units with the  key.

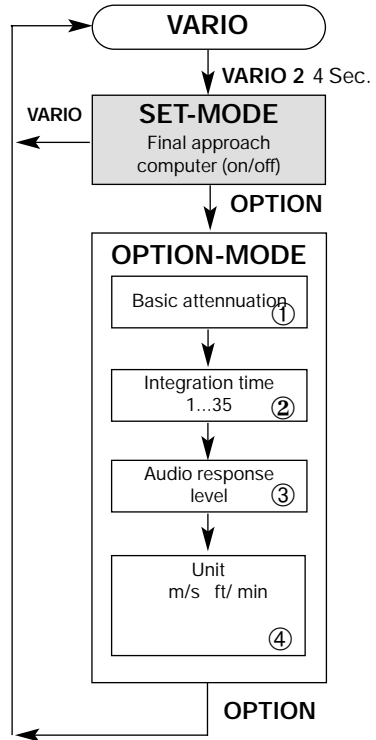

Descent tone/Descent alarm and Polar

The descent tone is a continuous tone dependent on descent which sounds as soon as descent is greater than the response point. The descent tone can be set or switched off with the  key. When the descent tone is active, the SINK indicator is displayed. When the descent tone is first switched on, a mark appears in the bar display indicating the response point set.

Descent alarm and polar input setting mode

The response point of the descent alarm is set in the bar display using the keys. The response point can be set over the entire range of the display and also remains stored in memory after the instrument has been switched off.

Press the two OPTION keys simultaneously to enter OPTION mode.

Descent alarm and polar input option mode



Four polars can be defined and saved in OPTION mode of the sink alarm. For the polars, the descent values at the relevant horizontal speed (20 kmh to 120 kmh) must be set at intervals of 2 kmh. No supporting value can be omitted within the polars! The ends of the polars (too low and too high horizontal speeds) are marked by only descent values following with the magnitude of zero.

Activating the polars

Press the  key to activate one of the four polars. The polar number is displayed in the upper digital vario window. The polar selected remains activated after exiting OPTION mode.

Polar input

After selecting the polar, the relevant supporting values can be entered manually. Pressing the  key starts polar input at 20 km/h. The current horizontal speed is shown in the SPEED display.

The flashing display shows the corresponding descent value. The value can be entered in steps of 0.1 m/s with the  and  keys. Pressing the  key again increases the speed each time by 2 km/h up to 120 km/h.

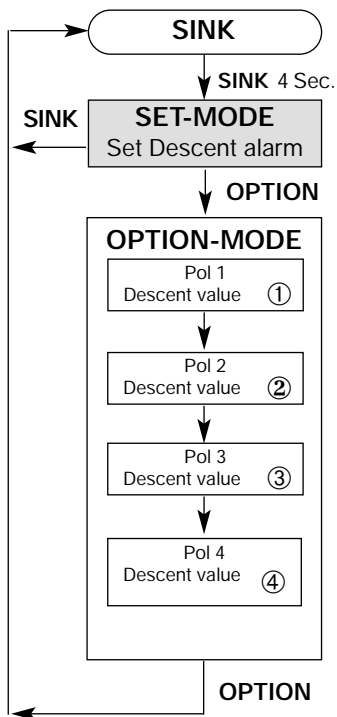

Saving the polars

The polar data is saved when you exit OPTION mode by pressing the two OPTION keys. NB: If no entry is made for 10 seconds, the unit automatically switches back into RUN mode without saving the amended polar!

Polar input via PC software

Polars can be entered more simply and more precisely with a PC and FLYCHART 4.XX Professional software.

Speedometer

General remarks

A speed sensor (speedometer) can be purchased as an accessory. The speed sensors in the 3000 series can also be used with instruments in the 4000 series.

The accuracy of a vane wheel sensor is highly dependent on its point of attachment.

Additionally, the individual probes have an accuracy of approximately + 2.5% (industrial standard) resulting from manufacturing operations and it is possible for two probes not to display exactly the same speed. These deviations can be largely corrected by the instrument. (\pm option mode of the speedometer).

Display



If a vane wheel sensor is connected to your instrument, speed (in kph, mph or knots) relative to the air can be shown in the lower display by pressing the  key.

When a stall alarm is switched on, a warning tone sounds when speed falls below a certain absolute speed. No stall alarm will sound at speeds that are below 10 kph. If the threshold is set at 10 km/h (or 5 mph), the stall alarm is switched off.

The current time can be shown every 30 sec in the SPEED display ( option mode of the speedometer).

If a probe always displays too much or too little, this deviation can be corrected at the fourth level of option mode.

Speedometer setting mode



In the speed indicator's SET mode, the horizontal wind component anticipated during final approach can be entered using the  key and the  key. It is required in order to calculate the optimum final approach moment. Positive values are interpreted as tail wind and negative values as head wind.



Press the two OPTION keys simultaneously to enter the OPTION mode

Option mode of the speedometer

The response threshold of the stall alarm can be altered at the first level. If the threshold is set at 10 kph (or 5 mph), the stall alarm is switched off.

At the second level, you have a choice of whether the time should be displayed automatically every 30 seconds when the speed display is switched on.

At the third level, the desired unit of the speed display is set. You can choose between kilometers per hour (km/h), miles per hour (mph) and knots (kts) by using the  key and the  key.

At the fourth level, you can also make adjustments to the correction of the speedometer. The correction value is given in percent using the  key and the  key. If the speed display is uncorrected, the display will show 100 (%). If the display still shows a 4% excessively high value (e.g. 50 km/h instead of 48 km/h), the display is corrected by setting 96 (%). This means that the display will now always show 96% of the original speed.

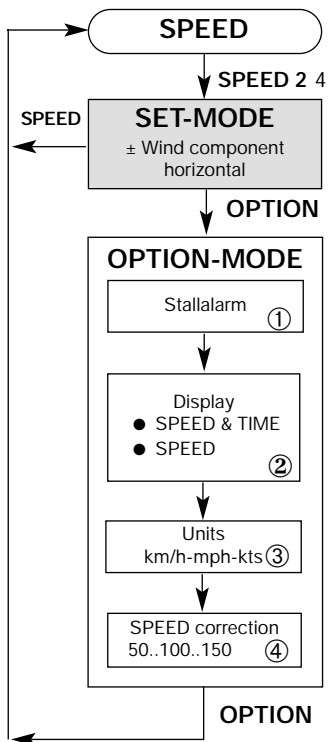





Time measurement and temperature display

Clock time (real-time clock)

In the lower display, the  key is used to toggle between speed, time and MEMO display. The time, the date and the year can be set in setting mode.

Stopwatch (CHRONO)

The stopwatch is displayed in the upper display. It can be started and stopped with the  key. If the stopwatch has been started, the indicator CHRONO will flash. Press key  to toggle between ALT 1, ALT 2 and CHRONO in the upper display. Press key  again to stop and start the stopwatch again. In order to reset a halted stopwatch, press the  key for 4 seconds. If the stopwatch has been halted, the CHRONO indicator remains displayed until the stopwatch has been reset.

Flying time





The flying time clock is automatically started after the instrument has been switched on and runs in the background independently of the stopwatch. The flying time is saved when the instrument is switched off. The flying time saved in memory is kept in the flight log. During flight, the flying time can be invoked in the MEMO display (♦ Logbook).

Temperature display

The temperature display is an additional function of the time display. The temperature display can be switched on or off. If the temperature display is switched on, the temperature is briefly shown every 30 seconds in the time display (the time interval can be set using the PC setup). The temperature display is switched on or off in option mode.

Please note: The temperature display reacts to changes in temperature with a slight delay as the temperature sensor is inside the instrument.



Time measurement and temperature display setting mode

The  key and the  key are used in setting mode to set the time. The hours and minutes are set first and confirmed with the  key. The date can now be entered in precisely the same way. This input is again confirmed with the  key. The year is also entered and confirmed in the same way.

Attention: As soon as the barograph display is activated with the REC switch and a flight has already been saved, the real time clock and the date can no longer be changed. They can only be manipulated again once the memory has been cleared ( Barograph setting mode).

Time measurement and temperature display option mode

The temperature display can be switched on or off at the first level of option mode. If it is switched on, the TEMP indicator will flash as well as a TIME indicator. When the temperature display is switched off, only the TIME indicator is on.

The unit of the temperature display (° Celsius or ° Fahrenheit) can be selected at the second level using the  key and the  key.

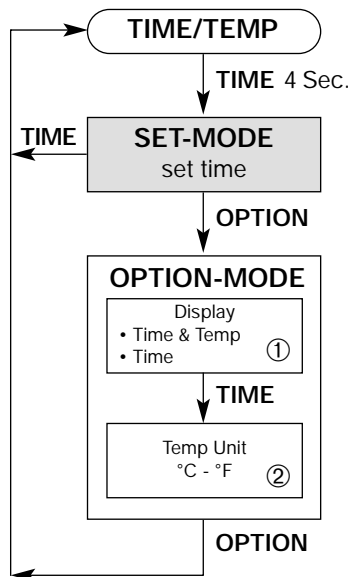

GPS-supported functions

Introduction

The following GPS-supported functions are integrated in the instrument:

- Desired flight according to MacCready
- Final approach calculator
- Glide ratio calculator

Naturally, the GPS functions can only be used if a GPS device is attached to the instrument and the GPS function in the instrument is activated (set to on)!

If speed or GPS data is incorrectly received, horizontal lines will appear in the display instead of this data. If the desired glide ratio is less than 1, the instrument will show "EE" instead of the desired glide ratio and "EEEE" instead of the target plus or minus flying altitude.

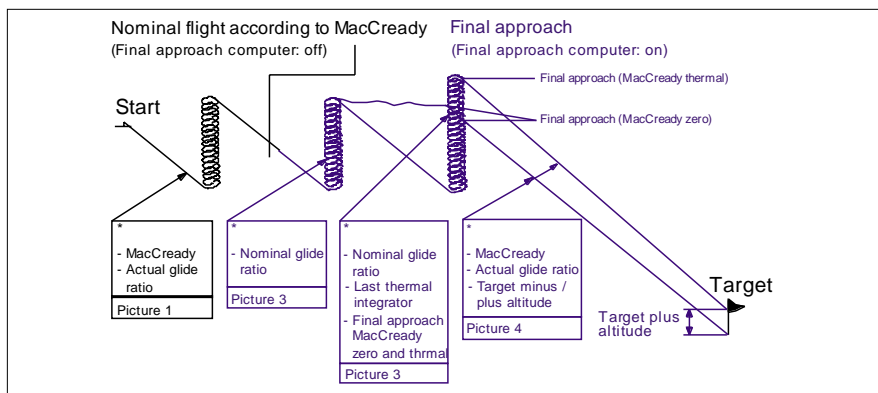

Basically, a flight consists of two phases. During the first phase, the flight is flown according to MacCready for an optimized desired flight and, during the second phase, the final approach is prepared and executed. To prevent the pilot being presented with a flood of information that is of absolutely no interest in the current phase, the 4030 only displays the interesting data of this phase to him. The user can activate and deactivate the final approach computer during the flight by pressing a key.

Connection to a GPS navigation receiver

Using a connecting cable (special accessory), a 4030 GPS can be connected to a standard GPS unit and will use the data supplied by the latter. In principle, all GPS receivers with standardized NMEA 183 interfaces are suitable although deviations to this between manufacturers are known.

Setting a GPS NMEA 183 interface

Baud rate: 4,800 baud
Interface: Input no, output yes
- Garmin: NEMA 183 version 1.5
- Magellan: NMEA 183b

For the final approach computer, a destination co-ordinate must be entered and activated with the GOTO or ROUTE function.

Normal flight according to MacCready**Theory:****Introduction**

In order to reach the highest possible cruising speed, the pilot must fly according to MacCready for cruise-optimized desired flight. Assuming that the pilot crosses a valley and expects a thermal with a climb rate of 2 m/s on the other side, he must select his cruising speed so that the bar of the MacCready display appears at 2 m/s during the glide phase.

If the bar only displays 1 m/s, he is flying too slowly and wasting precious time. If the pilot now notices that - at the speed selected - he is coming too close to the ground, he must fly more slowly. In an extreme case, at the speed for the best glide (that is to say with a MacCready display of 0 m/s), but never more slowly, as otherwise precious altitude is wasted!

Abbreviations

E: Glide ratio
 E_{max} : Maximum glide ratio attainable
 V_H : Horizontal speed (relative to the air: true airspeed)
 V_{VE} : Own descent
 V_{VL} : Vertical velocity of the air
 V_{FM} : Speed displayed by the airspeed indicator
 V_W : Wind speed
 V_{Sj} : Total descent ($V_{VE} + V_{VL}$)
 V_{St} : Effective rate of ascent in the thermal
 V_R : Cruising speed

The polar and its interpretation

In still air, the polar states the vertical speed of descent V_{VE} belonging to the specific horizontal speed V_H of a craft. V_{VE} is a negative value as it represents a downward movement. In the illustration: polar with and without a head wind (Polar with head wind: shaded co-ordinate system) shows an example of a polar.

The relevant descent value can be read from the polars for any flying speed (horizontal speed) and the relevant glide ratio can be calculated. $E = -V_H / V_{VE}$.

A straight line from the point of origin at any point on the polar represents (optically distorted by the choice of scale) the angle of inclination of the flight path at the particular speed.

From this, it can be deduced that the originating straight line which just touches the polar (tangent) has the flattest level of inclination and thus results in the best glide ratio. In the example: $V_H = 35 \text{ km/h} = 9.72 \text{ m/s}$ and $V_{VE} = -1.1 \text{ m/s}$. (The craft flies furthest at the flying speed with the best glide ratio.)

$$E_{MAX} = \frac{-9.72 \text{ m/s}}{-1.10 \text{ m/s}} = 8.84$$

The polar shown in the example is only valid if the air is completely still. The changes for air agitated horizontally and vertically will be discussed later.

The lowest descent speed can be determined with a horizontal tangent to the polar. In the example: $V_H = 30 \text{ km/h} = 8.33 \text{ m/s}$ and $V_{VE} = -0.97 \text{ m/s}$.

$$E = \frac{-8.33 \text{ m/s}}{-0.97 \text{ m/s}} = 8.59$$

Working out the polars

Since manufacturers' figures are generally over-optimistic, it is recommended that you work out the polars yourself. The polars are flown with the same equipment and the same instruments which will be used in subsequent flights. Instrument measurement errors can be neutralized in this way as they will also be present during normal flying later on. The polar worked out is thus a relative polar which is only correct for the instruments used and their displays, the absolute values of which may, however, be faulty. In order to achieve the same conditions, the airspeed indicator in particular should always be mounted in the same manner. The airspeed indicator should be calibrated as accurately as possible (e.g. with the help of the GPS receiver) to ensure that the flight instrument data is as precise as possible. Cf. OPTION mode of the airspeed indicator: SPEED correction.

For the purpose of information, it should be mentioned at this point that the speed V_{FM} indicated by the airspeed indicator does not represent the horizontal speed V_H but is composed of V_H and V_E .

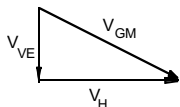

$$V_H = \sqrt{V_{GM}^2 - V_{VE}^2}$$

Polars for the best glide in still and agitated air

With a 20 km/h head wind, the polars are displaced by 20 km/h to the left. In order not to have to displace the polars, the origin of the co-ordinates in respect of the polars can also be displaced by 20 km/h to the right (blue co-ordinate system). The tangent from the new origin to the polar now touches it at the point at which $V_H = 40$ km/h and $V_{VE} = -1.21$ m/s. In other words for optimum glide, flight speed must be higher with a head wind than without a head wind.

If there was a following wind of 20 km/h, the origin of the co-ordinate system in respect of the polars would be displaced by 20 km/h to the left. If you also find yourself in a descending mass of air, the descent of the air must be included in the resultant overall descent and the polars should be displaced downwards by the relevant amount. Once again, the origin of the co-ordinates is displaced upwards and the tangent for the best glide is laid from there to the polar.

If, in our example, the 20 km/h head wind is accompanied by a descending mass of air of -1 m/s, the best glide is $V_H = 46.2$ km/h and $V_{VE} = -1.75$ m/s. The instrument would display an overall descent of $V_{Si} = V_{VE} + V_{VL} = -2.75$ m/s.

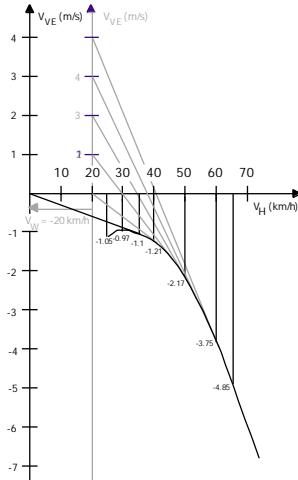

Illustration: polar with and without a head wind

Optimum cruising speed

Cruising speed in a mass of air that is not horizontally agitated can be calculated as follows:

$$V_R = V_H \cdot \frac{V_{St}}{V_{St} - V_{Si}}$$

V_{St} : Speed of ascent while circling in a thermal

V_{Si} : Overall descent in straight-line flight

The formula for the cruising speed can be graphically integrated into the depiction of the polars as shown in the illustration "Optimized desired flight".

Thus for our sample polar in descending air (-1 m/s), with ascending thermals of 1 m/s, the fastest flying speed would be $V_R = 25.3$ km/h at $V_H = 43$ km/h and an own descent $V_{VE} = -1.4$ m/s.

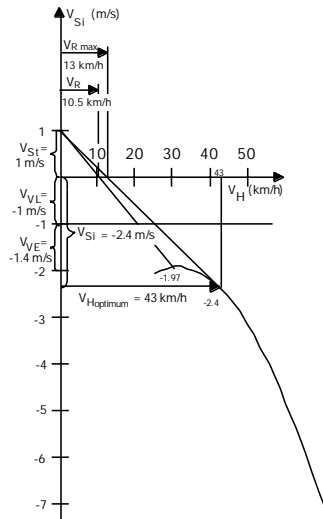

Illustration: Optimized desired flight

MacCready nominal flight display

The single bar in the upper part of the analog display represents the anticipated ascent in the next thermal. If a greater ascent is anticipated, you must fly faster; if a lower ascent is anticipated, you must fly slower.

The benefit of this type of display when compared with MacCready rings is that you do not have to touch the instrument during flight - changing your flight speed is sufficient.

Two arrows appear when the current actual glide ratio is displayed.

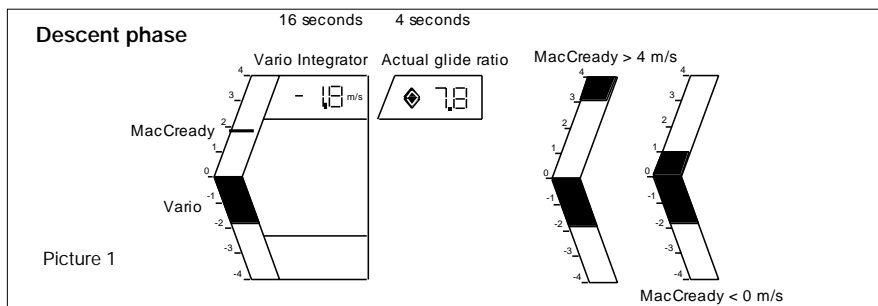

MacCready:

Anticipated ascent in the next thermal.

Vario and Vario integrator:

Is displayed in accordance with the VARIO OPTION mode.

Actual glide ratio:

Current glide ratio of the craft (computed with ground speed).

MacCready nominal flight instrument setting

GPS function on/off:

If the GPS function is set at off, all the instrument's GPS functions are switched off (q.v. ALT 2 OPTION MODE).

Polars:

4 polars can be saved in the instrument. The active polar is always the one that was displayed on the flight instrument before leaving SINK OPTION mode and not the one that was last loaded from the PC into the flight instrument. It is better to enter the polar data with a PC as the supporting values of the polars can be determined from saved calibration flights. The polar data can also be edited in the flight instrument. (q.v. SINK OPTION MODE).

Weighting of the wind component compensation: (0%, 25%, 50% and 100%). The tail wind or head wind component during the MacCready nominal flight is only taken into account at the percentage given here. For example: if the tail wind component is 30 km/h and if the weighting is set at 50%, the instrument calculates with an tail wind component of 15 km/h in the final approach. This value cannot be set in the instrument but only via a PC. Factory setting: 50%.

Final approach

Theory

Introduction

When the pilot is approaching his destination, it is important to find out when to start his final approach. He must begin it in quiet air as soon as the desired glide ratio harmonizes with the best glide of his craft (final approach according to MacCready zero). However, if he is already in a thermal, he can reach his destination more quickly if he climbs higher and the desired glide ratio is less than his best glide before he begins his final approach. He can then approach his destination at a higher speed (final approach according to MacCready thermal).

The distance used by the final approach computer always refers to the next waypoint that is being approached and the destination altitude set in the flight instrument is always used as the altitude. The final approach data is thus only meaningful if the next waypoint being approached is the destination.

If the pilot activates the final approach computer and approaches the destination at almost constant altitude, the flight instrument will signalize the moment for the final approach at MacCready zero (best possible glide). If the pilot enters a thermal shortly after, he should definitely exploit it as the flight instrument will calculate and signalize the new (better) moment for the final approach.

Final approach computer display

- A) Optimum glide ratio < nominal glide ratio
- B) Optimum glide ratio > nominal glide ratio (calculation of the optimum point in time for your final approach)

If the desired glide ratio corresponds to the craft's best glide ratio, taking into consideration

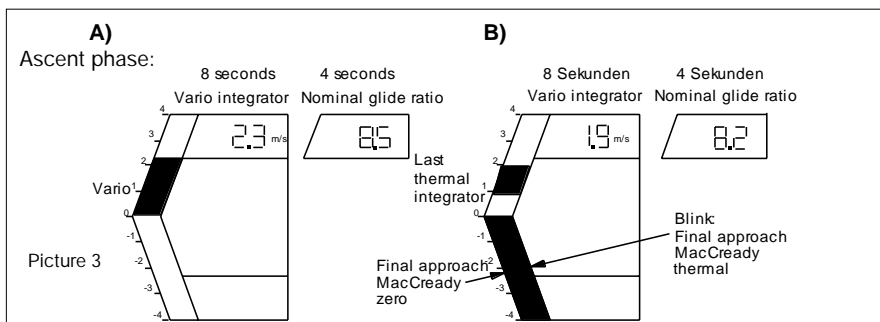

the following- and head-wind components, the flight instrument will then switch over from A) to B) and the lower part of the analog bar display will appear black (final approach possible). The last thermal integrator (the average ascent of the thermal) is shown in the upper part of the analog display and is slowly deleted from the bottom to the top until the right flight moment is reached. The entire lower part of the analog display then begins to flash. This is the moment of transition to the final approach.

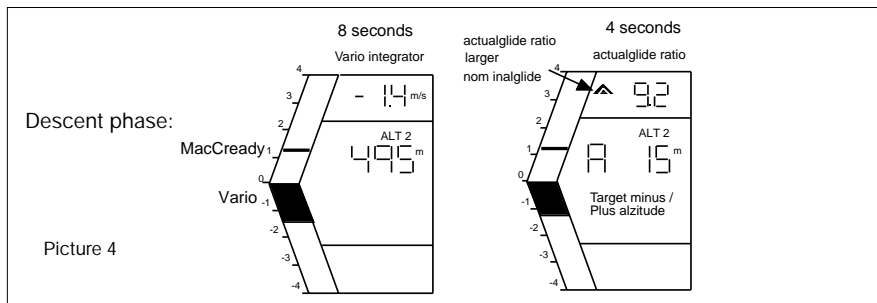

During the final approach, you must fly in such a way that the MacCready display in the analog display matches the last thermal integrator in the last thermal.

In addition, the plus / minus target altitude is displayed in ALT 2 as a check. If the pilot flies faster, it is reduced. The "A" that is displayed stands for "Approach". If he flies more slowly, it increases. If it becomes negative, the destination can no longer be reached at the current actual glide ratio.

Nominal glide ratio:

The glide ratio which must be attained to fly directly to your destination from your current position.

Target minus / plus altitude:

The altitude at which you will fly below or above your destination if you maintain your current glide ratio.

Last thermal integrator:

Ascent calculated over a longer period for the precise determination of the optimum point in time for your final approach.

MacCready:

Anticipated ascent in the next thermal.

Vario and Vario integrator:

Is displayed in accordance with the VARIO OPTION mode.

Actual glide ratio:

Current glide ratio of the craft (computed with ground speed).

Final approach computer: instrument settings

GPS function on/off: Set the GPS function to on (q.v. ALT 2 OPTION MODE).

Polars: Activate craft-specific polar (q.v. SINK OPTION MODE).

Target altitude: Target altitude input for final approach calculation (q.v. ALT 2 SET MODE).

Final approach computer on/off: Activates or deactivates the final approach computer (q.v. Vario Set mode).

Wind component: Corresponds to the wind component that the pilot expects in his final approach and is for the precise calculation of the time for the final approach. During phase 1, the wind component is calculated from the flight instrument and GPS data (q.v. SPEED SET MODE).



Logbook

General remarks

The maximum values of the current flight and those of the previous 19 flights are saved in memory and can be invoked in the MEMO display and printed out on a printer. You can access the MEMO display by repeatedly pressing the  key until the MEMO indicator appears.

The maximum values saved are:

- Maximum absolute altitude ALT 1
- Maximum relative altitude ALT 2
- Maximum ascent and descent VARIO bar display
- Flying time CHRONO
- Date Lower display

The  key and the  key are used to go through the flights saved until the flight required is displayed. Flight 0 is the current flight, the peak values of which are continuously updated. Flight 19 is the least recent flight and is deleted whenever a new flight is saved to memory.

The maximum values of a flight are saved to memory automatically when the instrument is switched off. (Condition: the instrument has been switched on for at least 3 minutes and a difference in altitude of at least 50 metres has been attained.)

Printout

The logbook can be printed out straight from the instrument via a printer cable onto a printer. Either a serial or a parallel cable must be used dependent on the printer. The printout is started by pressing and holding down the  key in the MEMO display, make sure that the MEMO shows flight 0.

Sample printout:

DATE	TIME	ALT11	ALT12	VARIOMETER		REC	Barogram	Sample
Nr.dd.mm.yy	hh:mm	MAX	MAX	MAX	MIN	TIME		TIME
1. 03.01.95	11:23	2032	204	1.2	-14.6	00:33	ALT TEMP	15
2. 05.01.95	13:45	1892	349	2.5	-12.3	01:26	ALT SPEED	15
3. 12.02.95	12:03	1580	89	0.8	-9.8	00:23	NO	-
4. 03.01.95	11:23	2032	204	1.2	-2.0	01:09	ALT	15
Nr.dd.mm.yy	hh:mm	[m]	[m]	[m/s]	[m/s]	hh:mm		[sec]

Barograph

Recording

Recording is done with the REC switched on. The saving rate is adjustable (1, 5 or 15 sec), as well as the magnitudes to be saved. (Cf. OPTION mode MEMO). The accuracy of the 4 magnitudes is: altitude = 1m, SPEED = 1 km/h, VARIO = 0.1 m/s, TEMP = 1°C. With altitude recording at 15-second saving rate, the maximum saving time is > 50 hours. (Larger memory available on request). Switching off the REC switch stops the barograph recording process and saves the flight in memory. If the REC switch is not switched off, the current recording is saved when the instrument is switched off.





IMPORTANT: If the REC switch is not activated, there will be no barograph recording; consequently, only the flying time and the peak values will be saved when the instrument is switched off.

Time marker

While a flight is being recorded you can set time markers in the barogram during the flight. For example, the turning-point can be recorded in the barogram. These markers are plotted in the printout and displayed in the FlyChart software. While a flight is being recorded you can set time markers by pressing the  key (the indicator must be on ALT1 or CHRONO) until a number appears briefly in the upper display. This is the number of the markers that have been set.

Printout

The barogram can be printed out directly on any EPSON-, IBM- or HP-compatible printer. (For printer selection, please refer to OPTION mode MEMO). Either a parallel (Centronics) or a serial (RS232) cable (special accessory) is required according to the type of printer used.

Switch the instrument to MEMO mode with the  key. Select the flight you require from the log-book list by pressing the  key and the  key. NB: you can only print out flights which have an ALT mark in the barogram column. No VARIO, SPEED or TEMP recordings are printed out in a direct printout. Start a printout by holding down the  key in the MEMO mode display (REC switch must be switched off). The altitude scale is automatically adjusted (2,400, 4,800 or 9,600m) in the printout.



Transmission to a PC

The **flights** recorded can be transmitted to a PC. You will require a PC with Windows 3.X or Windows® 95, a PC cable and Flytec's software.

Transmission is started from the PC Software FlyChart. It is required that the instrument is in the run mode on the MEMO display (flighth 0). The entire flight memory is then transmitted to the PC where the flights can be saved and printed out. The PC software can be used to print out a colour graphic of the barogram VARIO, SPEED and TEMP data.

Barograph setting mode

In setting mode, all flights in the logbook can be deleted and the recording interval of the barograph can be set.

In setting mode, the recording interval saved is displayed first. Using the  key or the  key, change in the MEMO display between the recording intervals 1, 5, 15 sec and CI. Briefly press MEMO to save the interval displayed and thus leave setting mode.

If CI appears in the MEMO display, all the flights can be deleted by pressing the  key for 4 seconds. As soon as the memory has been deleted, all the segments of the display will flash briefly and the instrument starts up again.



Barograph option mode

The magnitudes which the barograph is to record are set at the first level of option mode.

Use the  key or the  key to toggle between the different possibilities. The magnitudes to be recorded flash in the display:

- ALT 1 and SPEED Altitude and speed
- m/s ft/min x 100 and SPEED Ascent and speed
- ALT 1 and TEMP Altitude and temperature
- ALT 1 Altitude only

The **printer emulation** must be given at the second level of the OPTION mode:

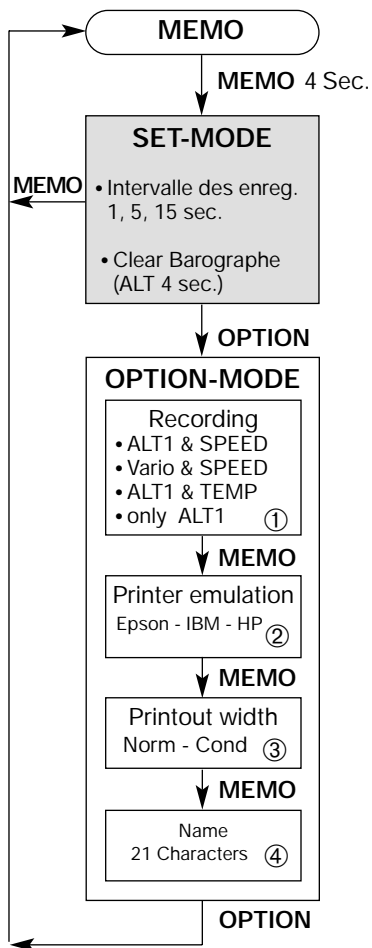

- EP  Epson FX-80
- lbm  IBM Proprinter
- HP  HP Deskjet



These two emulations are offered by the majority of standard dot impact printers.

The width of the printout (either condensed mode or normal mode) can be selected at the third level:

- | |-- ▶ condensed mode (double width)
- | |- ▶ normal mode

At the fourth level, you can enter your **name**; the name entered appears on the logbook printout. The individual letters of the name must be entered individually as ASCII code (▶ ASCII table in the appendix). The letter displayed is confirmed with the  key and the next displayed. The name may be 21 characters long. The number of the character appears in the digital vario display and the ASCII code for the character is shown in the MEMO display. Press the  key to enter the next character. Press the  key to return to the third level of option mode.

Press both option keys to return to run mode.

APPENDIX

Scope of supply

The following items are included:

- FLYTEC 4030 instrument
- Leg clip
- Protective sleeve
- Manual
- PC software and PC cable

The following are available as accessories:

- Various attachment fixtures
- Various speed sensors
- Printer cable (serial or parallel)

Procedure for Official FAI Observers

1. The observer must familiarize himself with the instrument for a period of at least 1 hour
2. At the take-off site, the observer must note the pilot's name and the type and serial number of instrument to be used. He must verify that the case is intact and undamaged. He must inspect both Flytec seals on the back of the unit and ensure that they are in place and undamaged.
3. The observer must switch the instrument on and check that the time, the date and the take-off altitude have been set correctly. If any of these values are incorrect, the observer must set them to the correct value (♦ setting mode altimeter 1.) The time has to be corrected in the time measurement display setting mode.

ATTENTION: The real time clock and the date can no longer be altered once the barograph recording has been activated with the REC switch. These two functions can only be reset when the memory has been cleared (♦ setting mode of the barograph).

4. The observer must switch the barograph on (REC).
5. The observer must continuously observe the pilot until take-off and verify that the pilot takes off with the instrument. The observer must note the exact time of take-off using an independent timepiece.
6. After landing, the pilot must set the REC switch and then the instrument to Off.
7. Printout: The observer must verify that the instrument displays the correct time and date and note any discrepancies with respect to local time. The observer must verify that the instrument is intact. He must also inspect both seals and ensure that they are undamaged. He must ensure that the instrument is connected directly to the printer by a single cable. The observer must also verify that nothing else is connected to the printer, e.g. an additional cable or instrument. Connection of the printer to the electrical mains is, however, permissible. The observer must verify that the printer paper is blank.
8. The observer starts the printout of the flight record and verifies that the Instrument number printed out is identical with the number noted at take-off. The observer must also verify that the time of take-off and the date in the printout agree with his records. The observer must be present during the entire printout procedure. When the printout is finished, the observer must remove the entire printout from the printer and add the date and his own signature.

The observer must ensure that FAI regulations are adhered to.

Water damage

If the instrument is damaged by water, remove the batteries at once. In the case of salt water, rinse the instrument thoroughly with handwarm fresh water. Then leave the instrument to dry out and send it as soon as possible to your FLYTEC dealer or to FLYTEC itself for checking.

Warning: Never try to dry it out in a microwave oven!

ASCII-table

32		52	4	72	H	92	\	112	p
33	!	53	5	73	I	93]	113	q
34	"	54	6	74	J	94	^	114	r
35	#	55	7	75	K	95	_	115	s
36	\$	56	8	76	L	96	`	116	t
37	%	57	9	77	M	97	a	117	u
38	&	58	:	78	N	98	b	118	v
39	'	59	;	79	O	99	c	119	w
40	(60	<	80	P	100	d	120	x
41)	61	=	81	Q	101	e	121	y
42	*	62	>	82	R	102	f	122	z
43	+	63	?	83	S	103	g		
44	,	64	@	84	T	104	h		
45	.	65	A	85	U	105	i		
46	.	66	B	86	V	106	j		
47	/	67	C	87	W	107	k		
48	0	68	D	88	X	108	l		
49	1	69	E	89	Y	109	m		
50	2	70	F	90	Z	110	n		
51	3	71	G	91	[111	o		

PC and printer interface

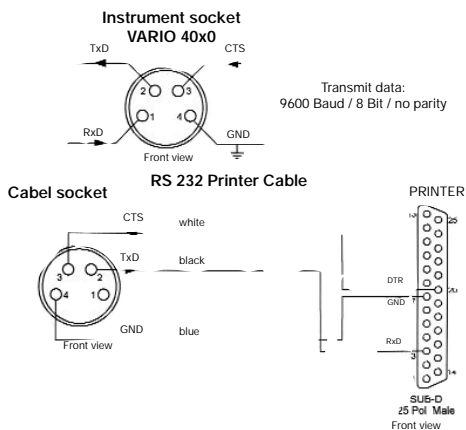

Funktion overview

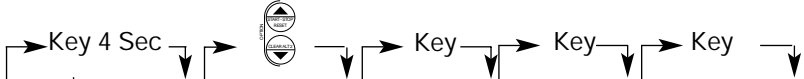

RUN Key	SET	OPTION			
		Level 1	Level 2	Level 3	Level 4
ALT 1	Altitude-setting ALT1	Units ALT1 (m/ft)	Pressure units	Sensor correction	
ALT 2	Altitude-setting ALT2	Target altitude	GPS on/off	ALT 2 Units (m/ft)	Absolut- or relative altitude
CHRONO	Reset				
SPEED	± Wind component horizontal	Stall alarm *	Time display	SPEED units	SPEED correction
TIME	time, date, year	Temperature display	Unities TEMP		
MEMO	Clear MEMO (ALT 4 Sec.)	Recording * parameters	Printer-emulation	Printout width	Pilot name
VARIO	Final approach computer on/off	Basic attenuation	Integrationtime	Audio response level	Units VARIO
SINK	Set Descentalarm	Pol 1 Alt → 20..120 km/h Descent value	Pol 2 Alt → 20..120 km/h Descent value	Pol 3 Alt → 20..120 km/h Descent value	Pol 4 Alt → 20..120 km/h Descent value

When the barograph is switched on the only changings that can be done are marked with an asteriks (*)

Markers (in the barogram) can be set by pressing the key  for 4 seconds.
The OPTION-Mode is locked with the barograph switched on.

Allgemein: Sollte es nicht heißen "speed indicator" statt "speedometer" ??
Ebenfalls: "km/h" statt "km/h" (beide kommen vor!)

1

Introduction

Connection to a GPS navigation receiver

Setting a GPS NMEA 183 interface

(Korrektur im englischen Text: NMEA statt "NEMA" auf Seite 18)

4

3. Glide ratio display

8. Speed sensor Socket

9. PC, printer and GPS interface

5

..... the relevant function key for approximately 3 seconds.

6

..... and option modes as well as additional configurations can

11

You can enter the vario's setting mode by holding down the \$\$ key (for approximately 3 seconds).

This automatically activates the final approach computer (on) or, if pressed again, deactivates it (off). The preset wind component is shown in the SPEED display for the purpose of information.

13/14

Descent alarm and polar input setting mode

Descent alarm and polar input option mode

Four polars can be defined and saved

Activating the polars

Press the \$\$ key to activate one of the four polars. The polar number is displayed in the upper digital vario window. The polar selected remains activated after exiting OPTION mode.

Polar input

After selecting the polar, the relevant supporting values can be entered manually. Pressing the \$\$ key starts polar input at 20 km/h. The current horizontal speed is shown in the SPEED display. The flashing display shows the corresponding descent value. The value can be entered in steps of 0.1 m/s with the \$\$ and \$\$ keys. Pressing the \$\$ key again increases the